

\*All resistors are in Ohms

Title		
TB193A 160-230MHz 300W 13dB		
Size	Document Number	Rev
A	Vds=50V, Idq=1.0A	A
Date:	Tuesday, March 15, 2005	Sheet 1 of 1

REVISIONS

REV	DESCRIPTION	DATE	APPROVED
	TB193A SR341 160-230MHz	03/15/2005	J. Citrolo

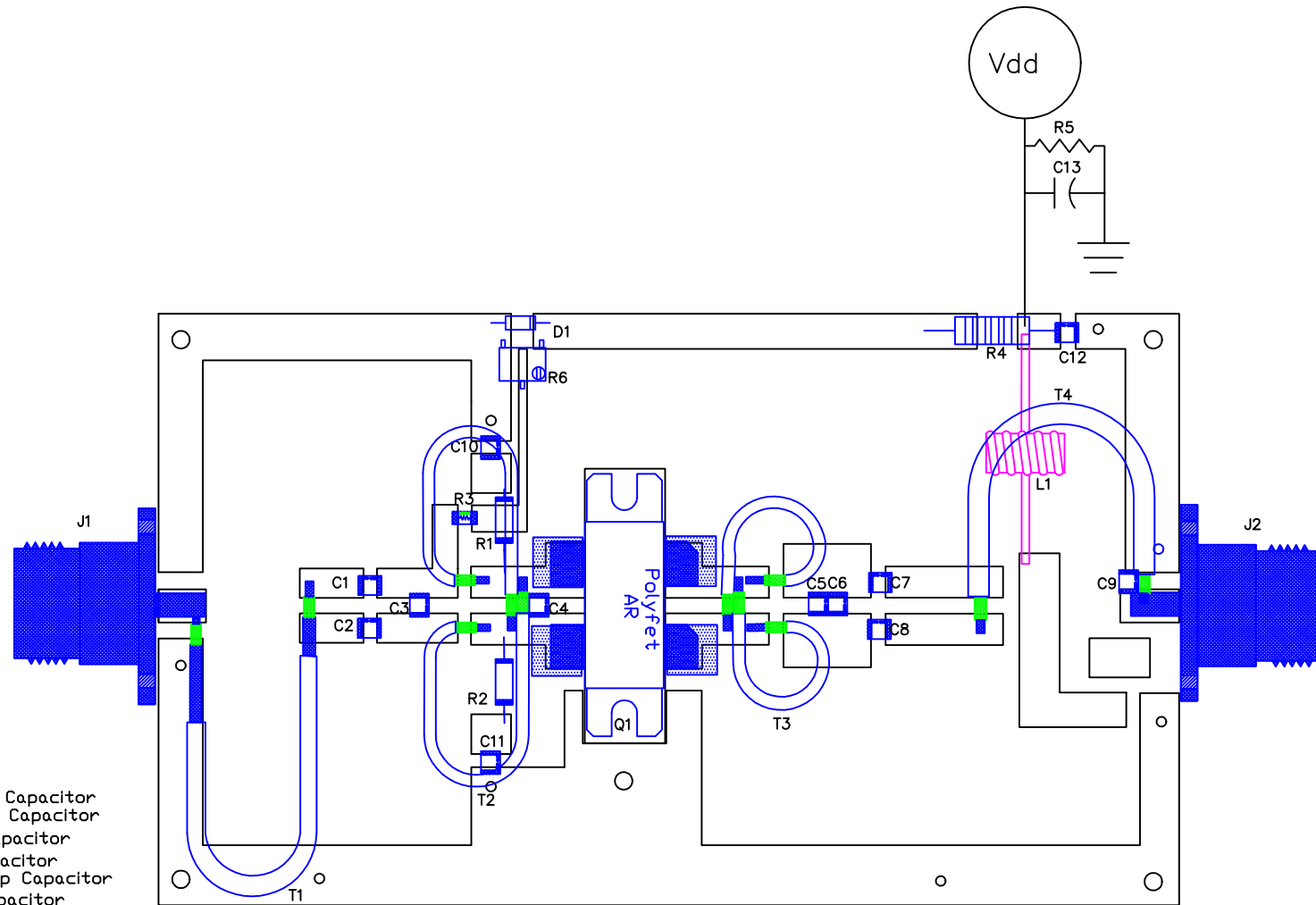

- C1, C2 = 51pF, ATC100B Chip Capacitor
  - C3, C5 = 13pF, ATC100B Chip Capacitor
  - C4 = 150pF, ATC100B Chip Capacitor
  - C5 = 11pF, ATC100B Chip Capacitor
  - C7, C8 = 240pF, ATC100B Chip Capacitor
  - C9 = 9.1pF, ATC100B Chip Capacitor
  - C10, C11, C12 = 0.01uF, ATC200B Chip Capacitor
  - C13 = 47uF, 100V Electrolytic
  - L1 = 18AWG, 850mu, 11-turn
  - R1, R2 = 16 Ohms, 1/4W Axial
  - R3 = 10K Ohms, 1206 Surface Mount
  - R5 = 10K Ohms, 1/4W Axial
  - R6 = 10K Ohms, multi-turn 6mm PDT
  - Q1 = SR341, Polyfet Push-Pull Transistor
  - T1 UT50-56, Length=3.2in
  - T2 UT34-17, Length=2.1in
  - T3 UT85-15, Length=2.1in
  - T4 UT141-50, Length=3.0in
- \* Tabs are in place on the drain and gate pads for production testing

DRN BY T. Chang	POLYFET RF DEVICES		
CHKD			
ELECT J. Citrolo	PCB LAYOUT		
MECH E. Cunningham	TB193A 160-230MHz 300W 13dB		
PROC	FSCM NO.	REV	
QUAL	A	SR341 50V <sub>ds</sub> 1.0A	
PGMS	SCALE: 1:1	SHEET 1 OF 1	

